

KMB-70 Instruction Manual



CONTENTS

- I、Installation01
- II、Operation06
- III、Spec and Parameter07
- IV、NMEA2000 Parameter Group Number(PGN)07
- V、SAE-J1939 Parameter Group Number(PGN)08
- VI、Attentions08

The KMB-70 Series is an Integrated Data Monitor with an advanced TFT (Thin Film Transistor) screen. The KMB-70 displays real time network information including engine output, fluid levels, and speed. KUS can also customize the unit to meet customer requirements. The unit is compatible with J1939 and NMEA 2000 systems. The KMB-70 is a perfect fit for marine applications that monitor information over the J1939 or NMEA 2000 network.

Installation

Method one, KMB be fixed on the desk and angle can be adjusted:

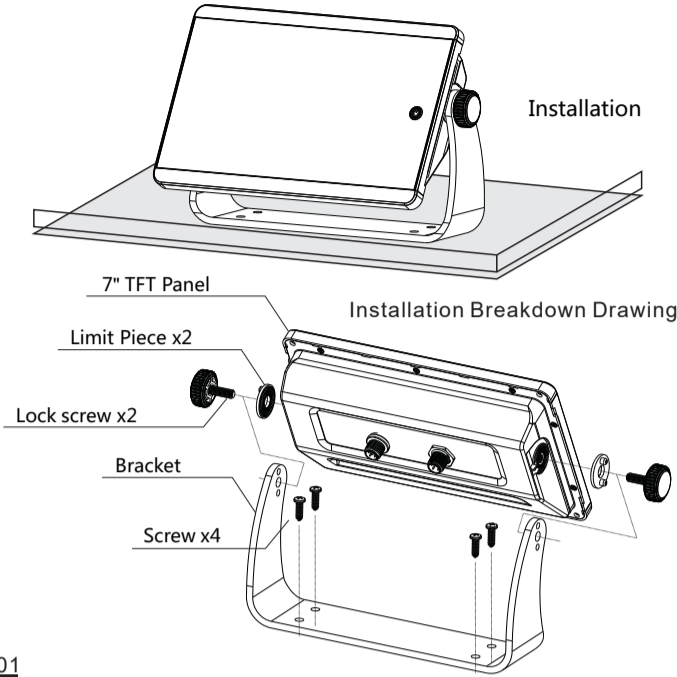

Method two, Install KMB gauge from upper side of panel as shown below:

- 1、Open one 199.3mm length and 116.3mm width hole. according to below screw position. Make sure the hole dimension are the same as shown below.
- 2、Install KMB gauge from top to bottom, adjust position, and lock screws.
- 3、After installation and the two trims can be removed (see installation drawing).
- 4、Connect the NEMA2000 wires on the back of KMB gauge to the NMEA2000 network.

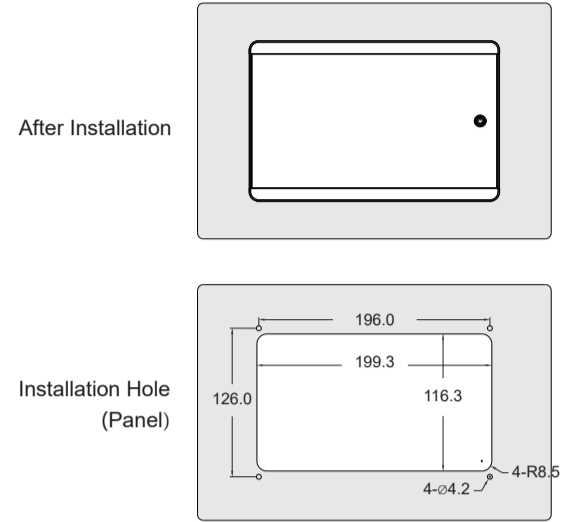

Installation Drawing

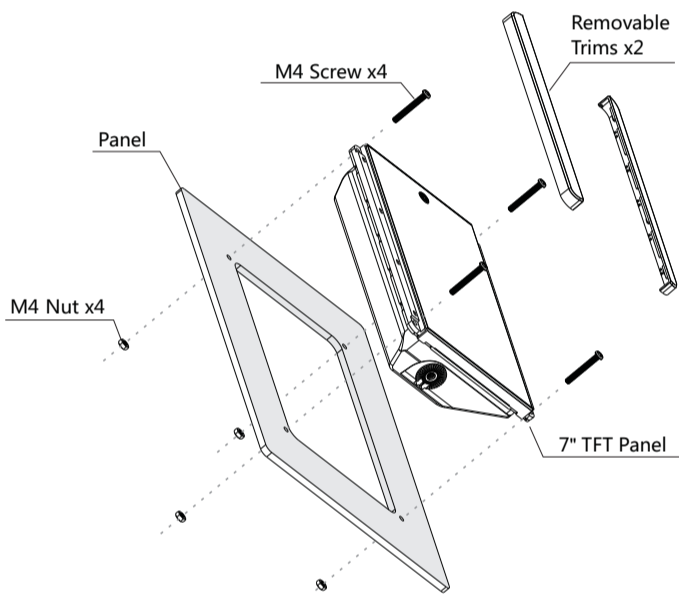

Method three, Install KMB gauge from bottom side of panel as shown below

- 1、Open one 212.9mm length and 114.4mm width hole. Make sure the hole dimension are the same as shown below.
- 2、Install KMB gauge from bottom to top, adjust position, and lock screws.
- 3、Connect the NEMA2000 wires on the back of KMB gauge to the NMEA2000 network.

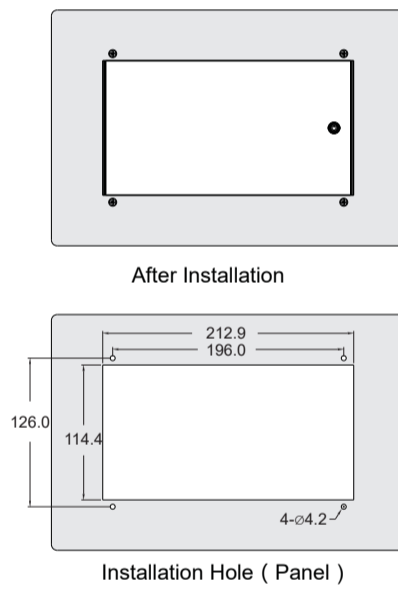

Installation Drawing

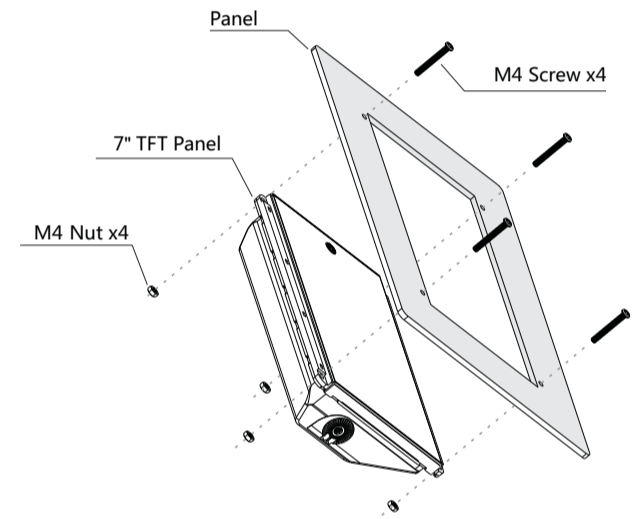

Display Screen Pin Corn

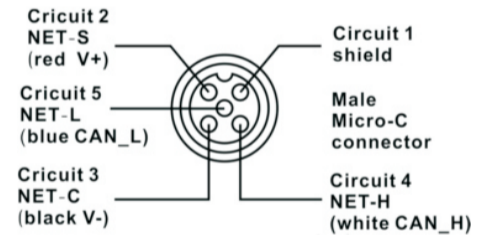

II、Operation

• Display Mode

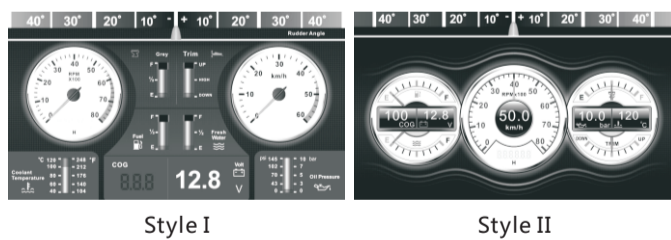

• Setting Mode

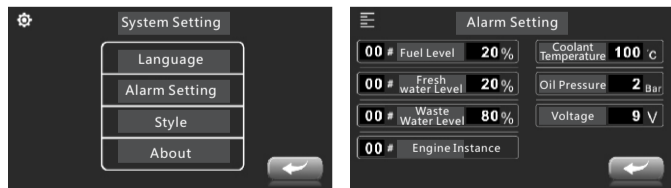

• Touch Screen Setting

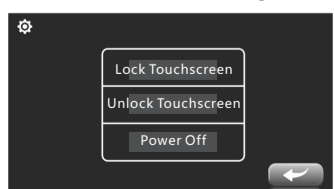

Press and hold the button on the right side of the touch screen to enter the touch setting interface.

Lock touch screen: enter the home screen display, select lock touchscreen.

Unlock touch screen: enter the home screen display, select unlock touchscreen.

Power off: press the shutdown button, the screen will turn off and lock. Hold and press the button again to turn on.

III、Spec and Parameters

Item	KMB-70
Size	7.0 inches
Resolution	800*480 pixels
Working Volt.	9-32V DC
Working Current	400mA(12V)
Working Temp.	-20°C~+60°C
Stock Temp.	-20°C~+70°C

IV、NMEA2000 Parameter Group Number(PGN)

PGN	DATA
127245	Rudder: Rudder Position
127488	Engine Parameters, Rapid Update: Engine Speed(RPM)/Engine trim
127489	Engine Parameters, Dynamic: Engine temp. Oil press./Total engine hours
127505	Fluid Level: Fuel level/Fresh water level/Black water level (Sewage)
127508	Battery Status: Battery Voltage
129026	COG & SOG, Rapid Update: Course Over Ground/Speed Over Ground

V、SAE-J1939 Parameter Group Number(PGN)

PGN	DATA
65279	Fuel level
61444	Engine Speed
65263	Engine Oil Pressure
65263	Engine Coolant Temperature
65253	Engine Total Hours of Operation

VI、Attentions

- 1、We recommend using KUS NMEA2000 series wires for connection, if you choose other wires, please refer to the connection diagram of pin above.
- 2、When wiring, please note that there is an eight-hole interface and a five-hole interface behind the display screen. The eight-hole interface is for debugging and the five-hole interface is for communication. Please connect to the five-hole interface correctly.



when the gauge is not in use, please put on the matched cover to protect the gauge.