

Product Data Sheet



Description: The NMEA tachometer gauge allows the user to remotely monitor to monitor the gear speed of their engine. These tachometer gauges will work with NMEA 2000 senders or resistive type senders with an analog converter.

Product Type: Water Tachometer Gauge

Product Name: NMHB

Bezel: SUS 316 Stainless Steel

Face Plate: Black White

Mounting Dimension: 85mm, 3 3/8"

Protection Rating: IP 67

Input Signal: NMEA 2000 & J1939

Indicating Range: 0 - 7000RPM

Operating Voltage: 12V/24V

Background light Red LED

Connector: Standard NMEA 2000 cable. 1 meter long

Movement: Cross coil motor movement

Installation Instructions

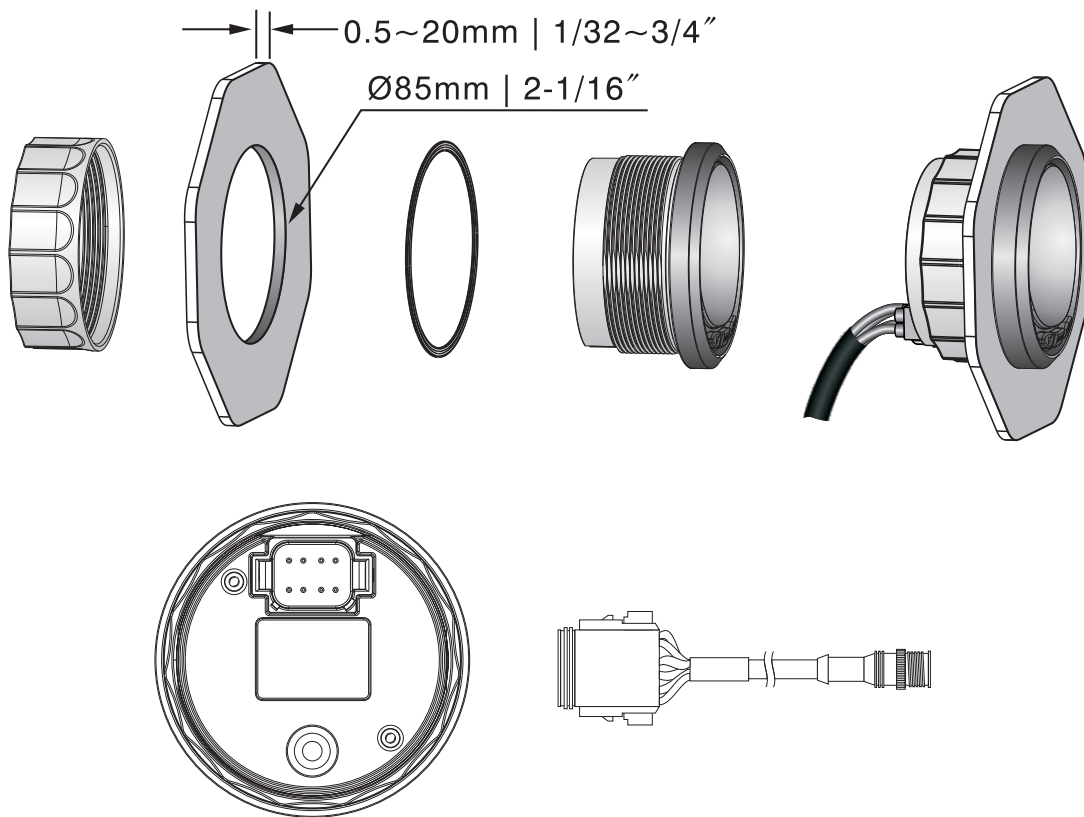

INSTALLATION STEPS

1. Cut a $\varnothing 85\text{mm}$ hole on the panel and ensure there is enough space behind the panel for gauge and harness mounting.
2. Assemble the seal ring into the gauge, then mount the gauge into the hole on the panel. Screw tightly with fastening ring.
3. Connect the cables as shown in the diagram.